

- 1 Electret, Amplified Dynamic Pilot Mike
- 2 Music Aux Audio Input
- 3 Electret, Amplified Dynamic Co Pilot Mike
- 4 Speaker Output - 4-8 Ohms
- 5 Intercom ON ground to operate
- 6 PTT Co Pilot
- 7 PTT Pilot
- 8 LED Backlight +12V
- 9 Positive 12 Volts
- 10 Positive 12 Volts
- 11 Pilot Isolate
- 12 Negative Ground
- 13 Headphone Output Co Pilot
- 14 Headphone Output Pilot
- 15 Speaker Output + 4-8 Ohms

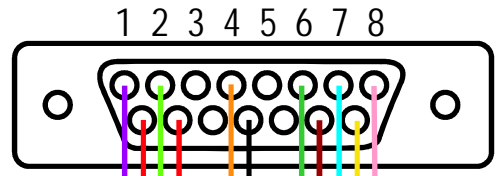

Db15 Female Plug
viewed from the rear

Music Input, CD-Player
MP3, Tape Deck etc...

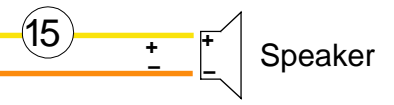
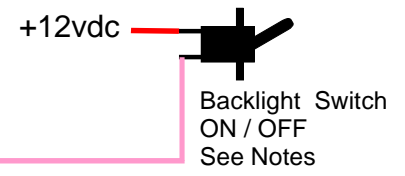

IMPORTANT NOTES

- ★ Speaker has a separate negative lead - do not ground the speaker as damage will result in the radio speaker amplifier !
- ★ 22,000 uF 25V Electrolytic Capacitor must be Installed if running off an engine driven power supply, the capacitor is not needed if the radio is only running off batteries.
- ★ The backlight switch is normally not needed in a glider and if left on will run your batteries down quicker, suggest using a PTT momentary on type switch rather than a toggle switch.
- ★ When using an XCOM Boom Mic please make sure to adjust the Mic Gain in the radio setup from the default value of 50 down to around 10 to 15 otherwise squealing will result, see page 2.
- ★ To save power consumption in the radio and make your batteries last longer turn off the intercom function in the radio setup screen, see page 2.
- ★ To include a flip flop and memory channel toggle wire the co-pilot PTT into your joy stick and adjust the setup to activate this feature, see page 2.
- ★ Page 2 accompanies this diagram and includes information on adjusting the radio for glider operations.

XCOM Radio Wiring Diagram Single Seat Glider V2
Copyright 2009 XCOM Avionics

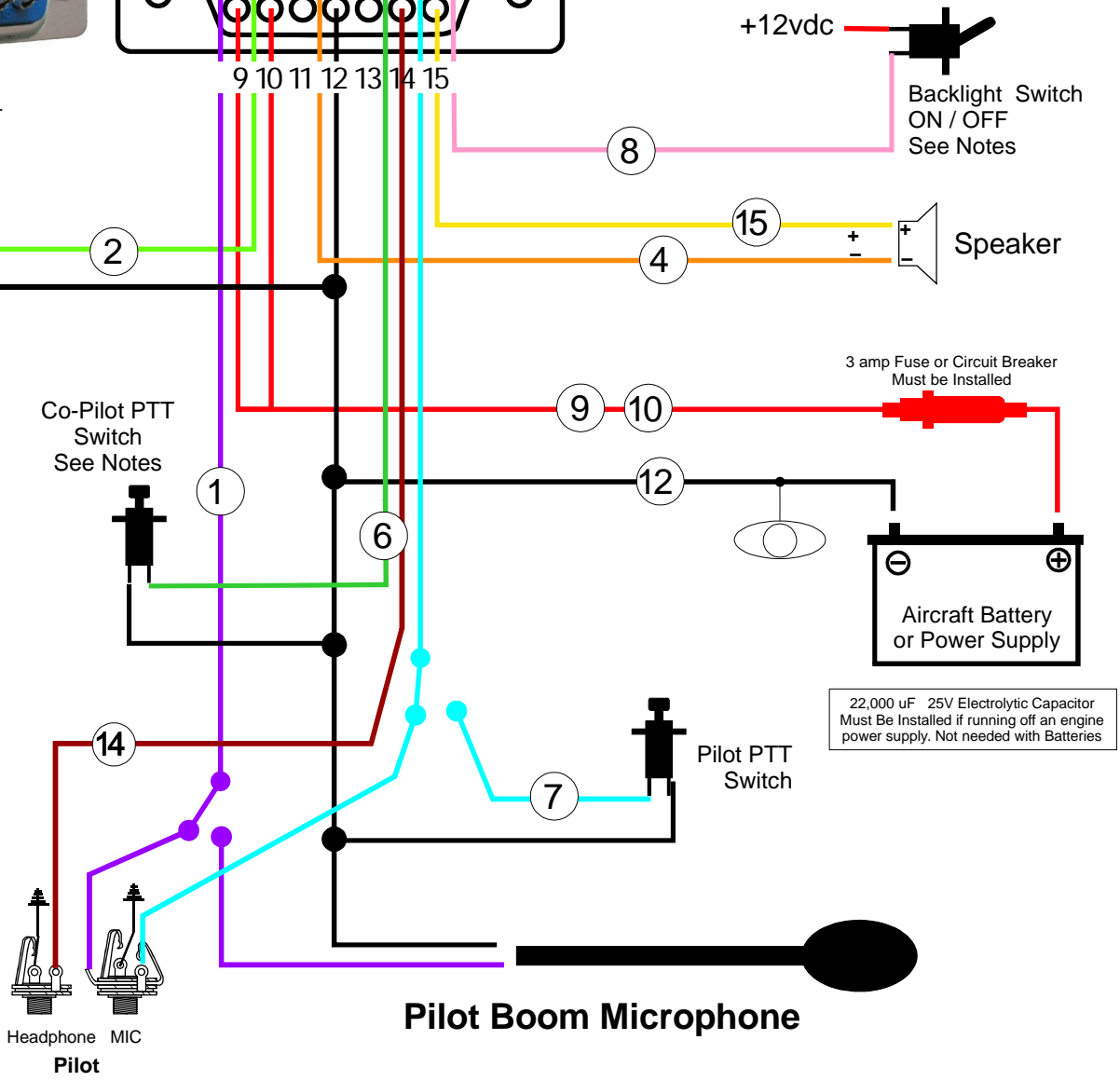

Single Seat Glider Wiring Diagram

This page describes the adjustments necessary to fine tune your XCOM radio for use in a single seat glider

Setting up the Boom Mic

To access the setup screens, turn the unit off using the ON button and, while holding the DUAL and MODE buttons, turn the unit back on using the ON button.

The current software version, will be displayed for a few seconds and then the unit will enter the setup mode.

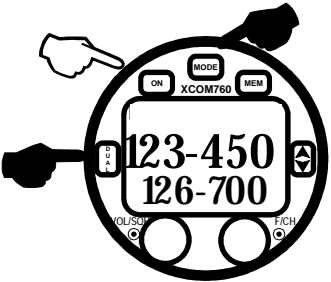

Press the F/CH knob several times to cycle through the options until **Gain** is displayed.

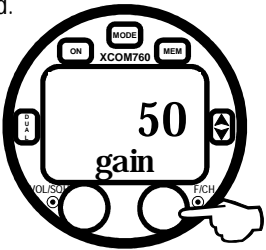

This setting adjusts the microphone gain. The default value will be set when the unit undergoes tuning prior to shipment and may vary slightly from unit to unit but it is normally set at the default value of 50 to suit normal aviation headsets.

Rotate the F/CH control to set the value down to 10 or 15 to suit the glider boom microphone.

Exit setup by pressing the **◆** button.

Turning the intercom OFF

To access the setup screens, turn the unit off using the ON button and, while holding the DUAL and MODE buttons, turn the unit back on using the ON button.

The current software version, will be displayed for a few seconds and then the unit will enter the setup mode.

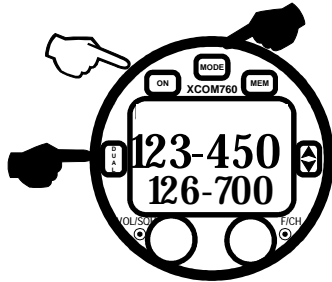

Press the F/CH knob one time so the option **INT** is displayed.

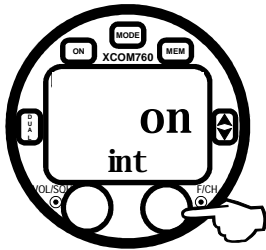

This setting turns the internal intercom on and off. The default value will be set to ON.

Rotate the F/CH control to turn the intercom OFF therefore saving power consumption.

Exit setup by pressing the **◆** button.

Setting up the remote toggle

To access the setup screens, turn the unit off using the ON button and, while holding the DUAL and MODE buttons, turn the unit back on using the ON button.

The current software version, will be displayed for a few seconds and then the unit will enter the setup mode.

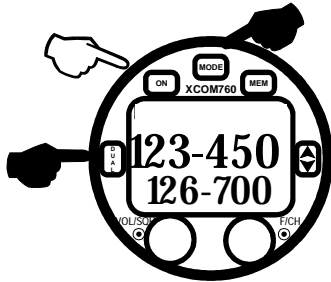

Press the F/CH knob several times until the option **PTT2** is displayed.



This setting determines the mode of operation of the copilot PTT switch. The default is ON.

In a single place aircraft, in helicopters or in aircraft where only one PTT switch is required, the copilot PTT can be used to toggle active and standby frequencies, in the default screen, or to cycle through memory channels, when in the MEM screen. When the PTT2 setting is on, the copilot PTT is active and when this setting is off, the copilot PTT acts as a toggle switch.

Rotate the F/CH control to toggle the setting On or OFF.

Exit setup by pressing the **◆** button.